

**RoHS**  
**2002/95/EC**  
  
**Compliant**

**PLAIN - EMC SEALED IP68**

PCB GUIDE	BOX SIZE (MM)				Screw Qty	Size	ORDER CODE		
	L	W	H	Plain			Powder Coated	Nylon Coated	
	88.9	34.9	30.5	4	A	480-C010	481-C010 **	482-C010 **	
	114.3	63.5	30.5	4	B	480-C020	481-C020 **	482-C020 **	
	114.3	88.9	55.9	4	C	480-C030	481-C030 **	482-C030 **	
	114.3	64.5	55.9	4	D	480-C040	481-C040 **	482-C040 **	
	171.5	120.6	55.9	6	E	480-C050	481-C050 **	482-C050 **	
	171.5	120.6	106.7	6	F	480-C060	481-C060 **	482-C060 **	
	222.3	146	56	6	G	480-C070	481-C070 **	482-C070 **	
	222.3	146	106.7	6	H	480-C080	481-C080 **	482-C080 **	
*	275	175	66	6	J	480-C090	481-C090 **	482-C090 **	
*	139.7	101.6	77	4	K	480-C100	481-C100 **	482-C100 **	
*	165	127	77	6	L	480-C110	481-C110 **	482-C110 **	
*	120	100	36	4	M	480-C120	481-C120 **	482-C120 **	
*	250	250	100.3	8	N	480-C130	481-C130 **	482-C130 **	
*	80	55	26	4	P	480-C140	481-C140 **	482-C140 **	
*	60	55	31	4	Q	480-C150	481-C150 **	482-C150 **	

\* Boxes with PCB guides      \*\* Colour option - Code Suffix: Grey = A    Blue = B    Black = E

**FLANGED - EMC SEALED IP68**

PCB GUIDE	BOX SIZE (MM)				Screw Qty	Size	ORDER CODE		
	L	L (exc Flg)	W	H			Plain	Powder Coated	Nylon Coated
*	114.3	89.2	35.15	30.5	4	A	483-C010	484-C010**	485-C010**
*	139.7	114.1	63.6	30.5	4	B	483-C020	484-C020**	485-C020**
*	139.7	114.2	63.7	55.9	4	C	483-C030	484-C030**	485-C030**
*	139.7	114.7	89.15	55.9	4	D	483-C040	484-C040**	485-C040**
*	202	171.8	120.8	55.9	6	E	483-C050	484-C050**	485-C050**
*	202	171.8	120.8	106.7	6	F	483-C060	484-C060**	485-C060**
*	252	222.6	146.4	55.9	6	G	483-C070	484-C070**	485-C070**
*	170	140	101.6	77	4	K	483-C100	484-C100**	485-C100**
*	152	120	100.2	36	4	M	483-C120	484-C120**	485-C120**

\* Boxes with PCB guides      \*\* Colour option - Code Suffix: Grey = A    Blue = B    Black = E

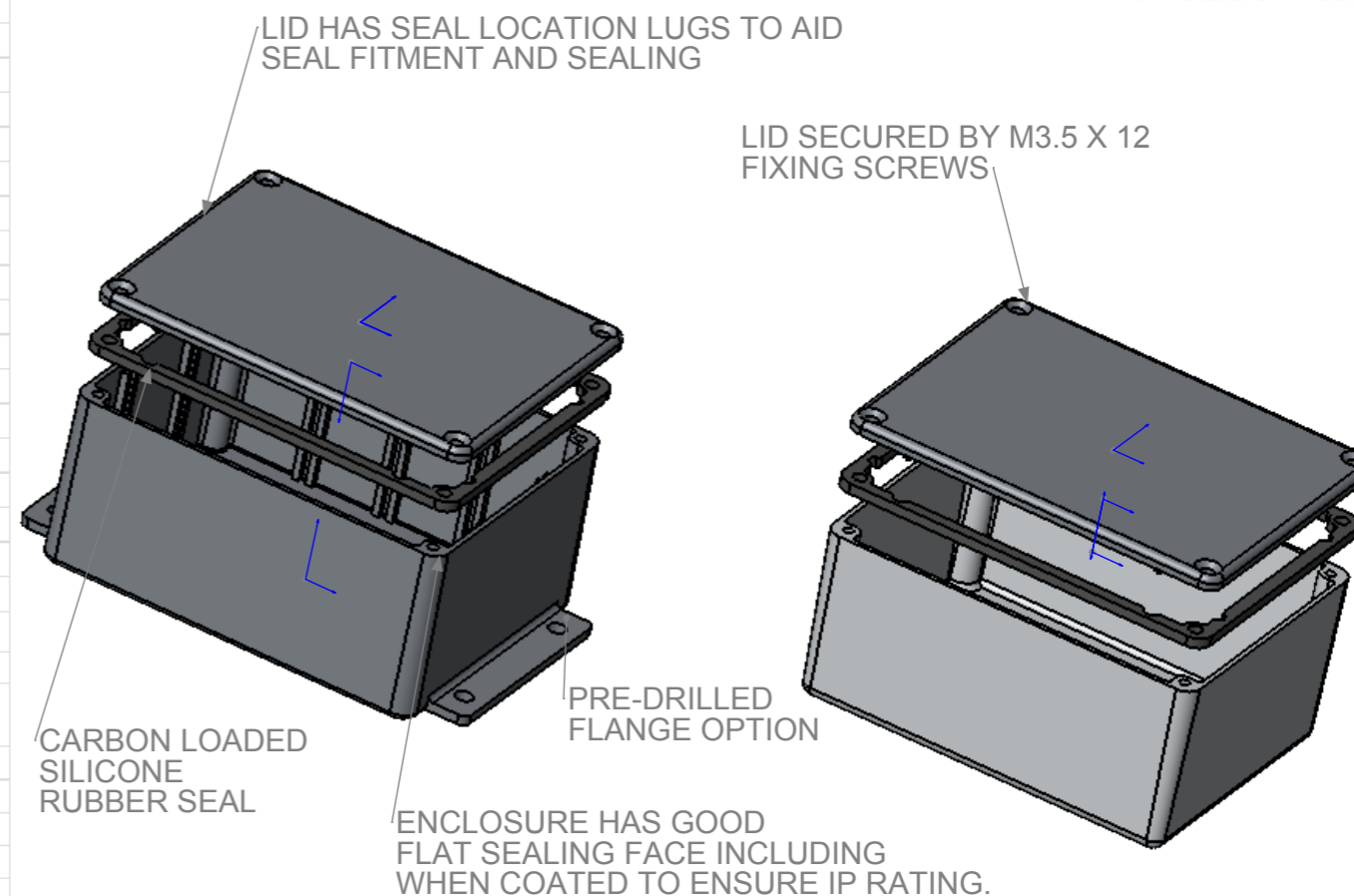

- A RANGE OF DIE CAST ALUMINUM ENCLOSURE SEALED TO BS EN 60529:1992 IP66, IP67 AND IP68 (5Mtrs for 1 hour)
- CARBON LOADED SEMI CONDUCTIVE SILICONE RUBBER SEAL AP701/2
- MIN SEAL THICKNESS 3.0MM - MIN SEAL FRAME WIDTH 4.0MM
- MIN ENCLOSURE WALL THICKNESS 1.5MM
- MIN ENCLOSURE LID THICKNESS 1.5MM

INTERPOLATED SIZES ARE PERMITTED PROVIDED THE MINIMUM CENTRES ARE MAINTAINED IN ACCORDANCE WITH THE 455/459 SERIES SPECIFICATION

<b>PROPRIETARY AND CONFIDENTIAL</b> THE INFORMATION CONTAINED IN THIS DRAWING IS THE SOLE PROPERTY OF <b>DEM MANUFACTURING</b> . ANY REPRODUCTION IN PART OR AS A WHOLE WITHOUT THE WRITTEN PERMISSION OF <b>DEM MANUFACTURING</b> IS PROHIBITED.	Drawn by W.COXON    27/05/09	UNLESS OTHERWISE SPECIFIED: DIMENSIONS ARE IN MILLIMETRES LINEAR TOLERANCES:	<b>A3</b>	TITLE: <b>GENERAL SPECIFICATION IP68 EMC RANGE OF ENCLOSURES</b>
	FINISH: <b>AS ABOVE</b>	THIRD ANGLE PROJECTION	NO DECIMAL PLACES    ±0.5mm 1 DECIMAL PLACE    ±0.1mm 2 DECIMAL PLACES    ±0.03mm	MATERIAL:
	DEBUR AND BREAK SHARP EDGES IF IN DOUBT ASK DO NOT SCALE DRAWING	ANGULAR TOLERANCES:    ±1°	SCALE: 1:2	ISSUE <b>A</b>
TEL: +44 1724 273200    E-MAIL: SALES@DEM-UK.COM    WEBSITE: WWW.DEM-UK.COM	WEIGHT: 4565862.094	SHEET 1 OF 1		