

26 KEY HANDHELD KEYBOARDS WITH "THUMBSTICK"



KBTS26

These 26 key handheld membrane keyboards have an integrated Hall effect joystick which we call a "thumbstick" (this name describes better its functionality). The keyboards are sealed IP65 and housed in a very stylish and robust ABS housing. They have numeric and function keys; the control keys are available via "Fn" key mapping.

Ideal for applications requiring only a limited number of key functions with fast and comfortable key access and a precise, thumb operated joystick which acts as a cursor controller.

Features

- 26 membrane keys with tactile feel, 1,4 mm travel and 4N operating force
- Integrated Hall effect joystick (acting as cursor controller)
- Very robust and stylish ABS housing for the enclosed version
- Front of panel mounting by six M3 mounting studs for panel mount version
- Adequate sealing into the customers panel by the added silicone sponge seal (panel mount version)

SPECIFICATIONS

- Sealing : IP65 sealed
- Keys : 26 tactile membrane keys
- Pointing Device : Hall effect thumbstick
- Output : 1,6 m. PS/2 or USB cable(s)
- Dimensions panel mount : 85 x 205 x 34 mm
- Dimensions enclosed : 105 x 210 x 60 mm
- Weight : 0,2 kg / 0,4 kg

CONNECTIVITY

The PS/2 keyboards are supplied with one 1,6 m long shielded splitted cable ended by two PS/2 plugs. The USB versions are supplied with one 1,6m long shielded straight cable ended by a USB type A plug.

Use the drivers standardly available in your operating system.

** Due to the increasing differences of PS/2 mouse port specifications of the various PC manufacturers, we do recommend that this unit should be tested on the final PC configuration and operating system prior to installing it in series.*

ORDER INFO

LAYOUT	PANEL MOUNT	ENCLOSED
N.a	KBTS26 F1 xxx	KBTS26 S1 xxx

xxx = protocol output : PS/2 or USB

26 KEY HANDHELD KEYBOARDS WITH "THUMBSTICK"

DIMENSIONAL DRAWING

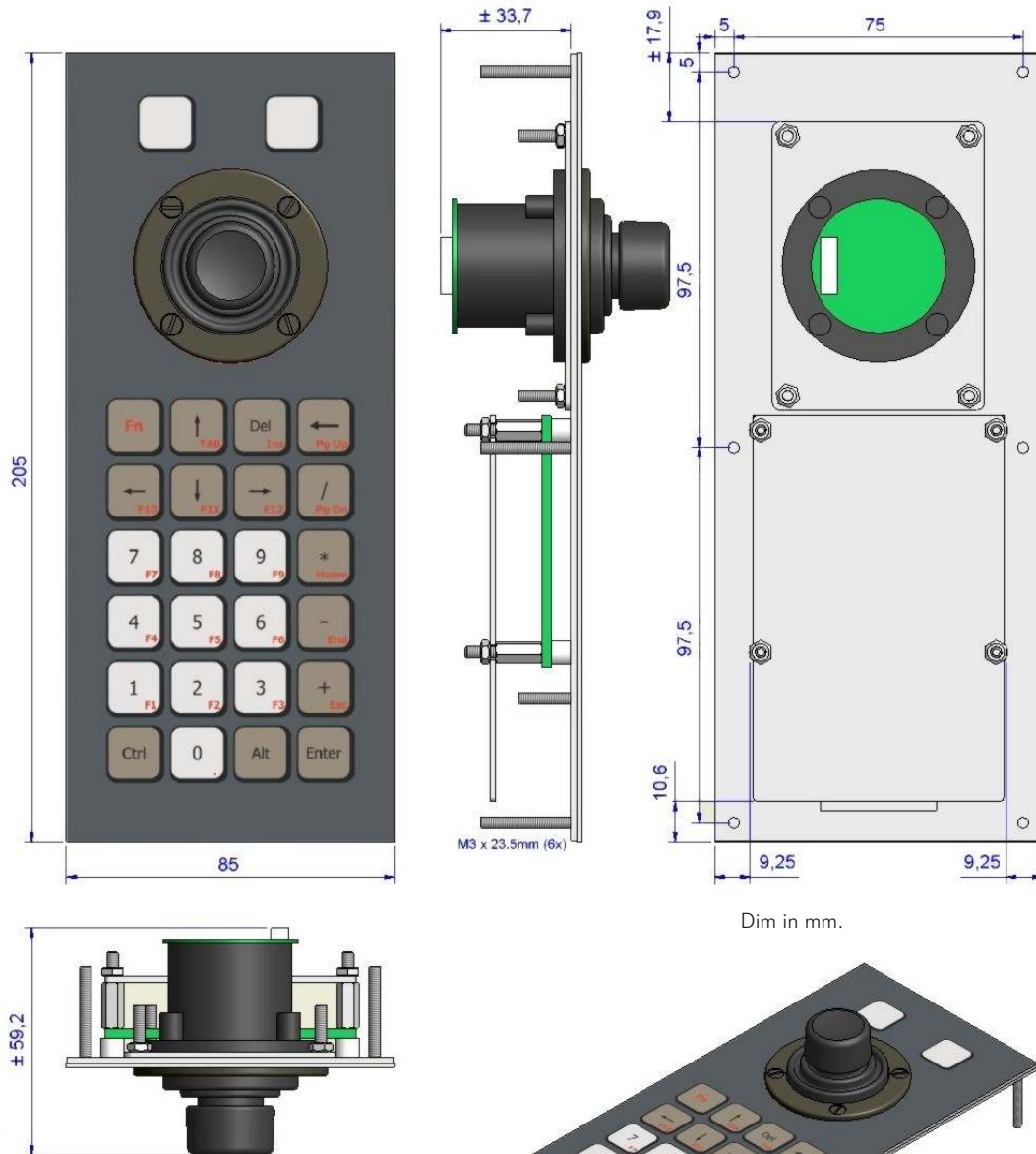

COLOURS

Background : RAL 7024 graphite grey

Keys : Contour : RAL 9011 graphite black

Legends : RAL 9011 graphite black or RAL 3000 flame red

Background : RAL 9006 white aluminium or RAL 9007 grey aluminium

The company reserves the right to alter without prior knowledge the specification or design of any standard product or service.