

**Table of Contents**

DS11 Series DC Relays, 2 Amp Output Rating,  
 Qualified to DSCC Drawing 88062 .....10-2 – 10-5

DS13 Series DC Relays, 2 Amp Output Rating,  
 Qualified to DSCC Drawing 90091 .....10-6 – 10-9

MS14 Series Solid State Relay .....10-10, 10-11

JTS5, 6, & 7 Series, DC & Bi-Directional Output, Up to 250mA & 250V Output Rating,  
 TO-5 Package, Qualified to MIL-PRF-28750/5, /6, & /7 .....10-12

MS18 Series, DC & Bi-Directional Output, Up to 2A & 350V Output Rating,  
 Qualified to DSCC Drawing 89116 .....10-13, 10-14

JDS9 Series, AC Relays, 2A/250Vrms Rating, Qualified to MIL-PRF-28750/9 ...10-15, 10-16

PS12 Series, AC Relays, 10A/250Vrms Rating,  
 Qualified to DSCC Drawing 86031 .....10-17, 10-18

JPS10 Series, AC Relays, 25A/250Vrms Rating,  
 Qualified to MIL-PRF-28750/10 .....10-19, 10-20

## DS11 Series SSR For DC Loads up to 2A @ 60Vdc

### Product Facts

- Standard options: short circuit/overload protection, switch status and trip status
- Optically coupled all solid state relay
- TTL & CMOS compatible input
- Low on-resistance power MOSFET output
- Tested per MIL-PRF-28750D and approved to DSCC drawing 88062 with "Y" level screening



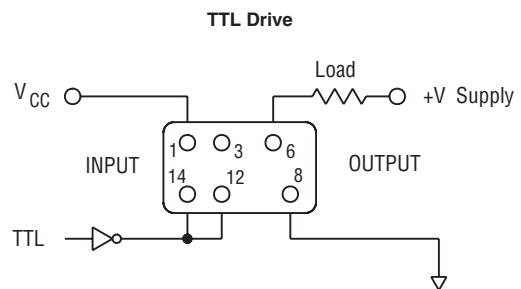
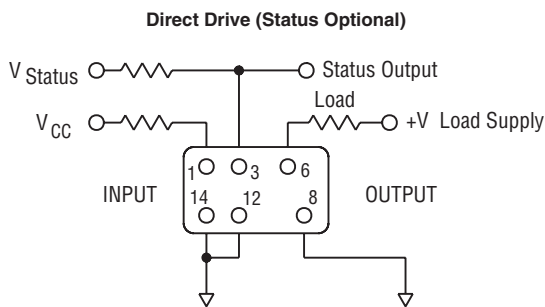
DS11 series SSRs feature state of the art photo-voltaic optical isolation and power MOSFET output chips for ultra-reliable high speed switching of DC loads up to 2 amps, with extremely low on-resistance. Standard options include integral current overload/short circuit protection to provide protection of the relay, load

and wiring; and isolated switch status or trip status. The overload feature provides protection if a short or overload develops while the relay is in the on state or if the relay is turned on into a dead short. Switch status, optically isolated from the load, signals the status of the output and provides a logic "0" when the output is

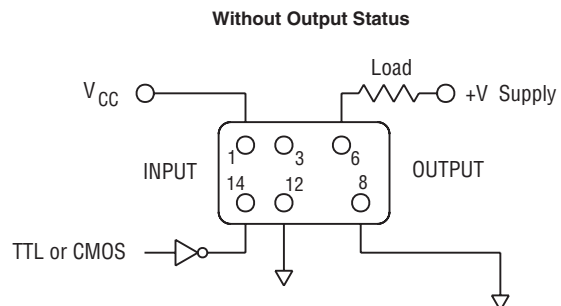
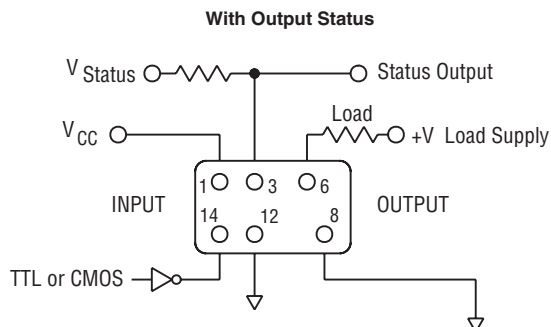
off and a logic "1" when the output is on. Trip status, also optically isolated from the load, provides a logic "1" if the output trips off and a logic "0" when the output is in a normal condition, on or off, and is available only in conjunction with short circuit protection.

Kilovac Part No.	DSCC Dwg. No.	Relay Version
<b>DS11-1Y</b>	88062-008	Basic relay
<b>DS11-1000</b>	88062-004	Relay w/ short circuit protection
<b>DS11-1001</b>	88062-006	Relay w/ switch status
<b>DS11-1002</b>	88062-002	Relay w/ short circuit protection and switch status
<b>DS11-1003</b>	N/A	Relay w/ short circuit protection and trip status

### 2 Terminal Input Configuration



### 3 Terminal Input Configuration



**DS11 Series SSR For DC Loads up to 2A @ 60Vdc** (Continued)

**Environmental Characteristics**

**Ambient Temperature Range** —

Operating — -55°C to +105°C  
Storage — -55°C to +105°C

**Vibration Resistance** —

100 G's, 10-3,000 Hz

**Shock Resistance** —

50 G's, 11 ms pulse

**Constant Acceleration Resistance (Y1 axis)** —

5,000 G's

**Mechanical Characteristics**

**Weight (approx.)** —

.176 oz. (5 grams)

**Materials** —

Header — KOVAR  
Cover — Nickel  
Pins — KOVAR, gold plated

**Electrical Specifications (-55°C to +105°C unless otherwise specified)**

**Input (2 terminal configuration)**

Input supply voltage range (Vcc)	3.8 - 32 Vdc (Notes 1 & 2, Figures 1 & 2)
Input current (max.) @ 5Vdc	15mAdc (Notes 1 & 2, Figures 1 & 2)
Must turn-on voltage	3.8Vdc
Must turn-off voltage	1.5Vdc
Reverse voltage protection	-32Vdc

**Input (3 terminal configuration)**

Control voltage range	0 - 18 Vd
Control current (max.)	250µAdc @ 5V, 1mA @ 18V
Input supply voltage range (Vcc)	3.8 - 32 Vdc (Notes 1 & 2, Figures 1 & 2)
Input current (max.) @ 5Vdc	15mADC (Notes 1 & 2, Figures 1 & 2)
Must turn-on voltage	0.3Vdc
Must turn-off voltage	3.2Vdc

**I/O**

Dielectric strength (min.)	1,000V rms
Insulation resistance (min.) @ 500Vdc	10 <sup>9</sup> ohms
Capacitance (max.)	10pF

**Output**

Continuous load current (max.) @ 25°C	2.1Adc (Figure 7)
Continuous load voltage (max.)	60Vdc
Transient blocking voltage (max.)	80Vdc (Note 5)
On resistance (max.) @ T <sub>j</sub> = 25°C, I <sub>L</sub> = 100mA	0.15 ohm (Note 6, Figure 6)
Output voltage drop (max.)	0.5Vdc
Leakage current (max.) @ V = 60Vdc	100µAdc
Leakage current (max.) @ V = 60Vdc, with switch status	2mAdc
Turn-on time (max.)	3 ms (Figure 3)
Turn-off time (max.)	1 ms (Figure 3)
dv/dt (min.)	100V / µs
Electrical system spike	600Vdc (Note 5)
Output chip junction temperature (max.)	125°C
Thermal resistance (max.), junction to ambient	90°C/W
Thermal resistance (max.), junction to case	25°C/W

**Status**

Status supply voltage range	1 - 18Vdc
Status current (max.) @ V <sub>status</sub> ≤ 0.4Vdc	600µADC (Figure 5, Note 8)
Status leakage current (max.) @ 16Vdc	10µAdc
Status turn-on time (max.)	3.5 ms (Figure 4)
Status turn-off time (max.)	8 ms (Figure 4)

**Short Circuit Protection**

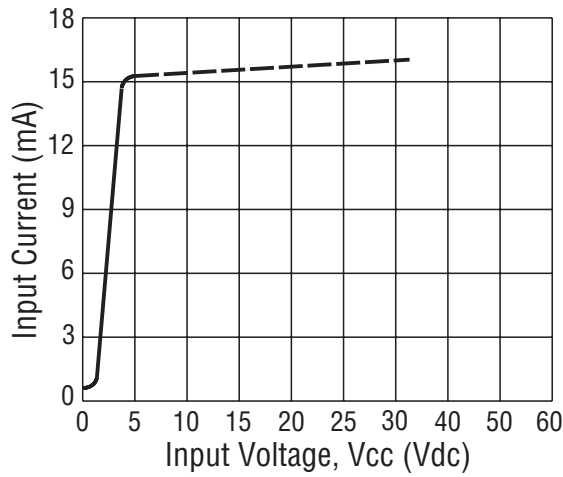
Current surge without tripping (max.), 100ms pulse	4.25Adc
Overload trip current (max.), 0.5 ms pulse, V = 60Vdc	10Adc
Trip time (typical), turning on into short	400µs
Trip time (typical), shorting while relay is on	280µs

10 Kilovac Solid State Relays

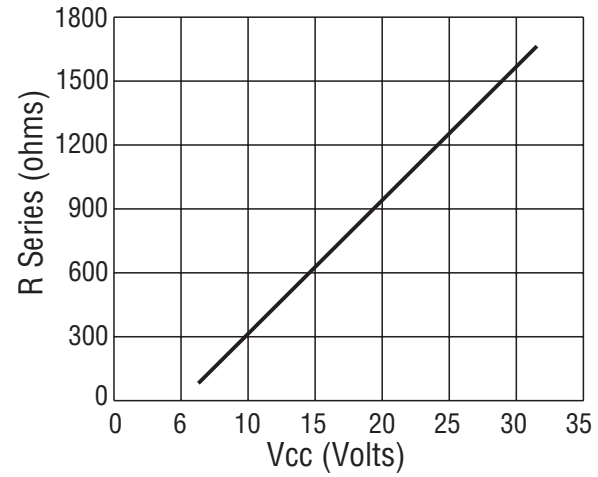
KOVAR is a trademark of Carpenter Technology Corporation.

**DS11 Series SSR For DC Loads up to 2A @ 60Vdc** (Continued)

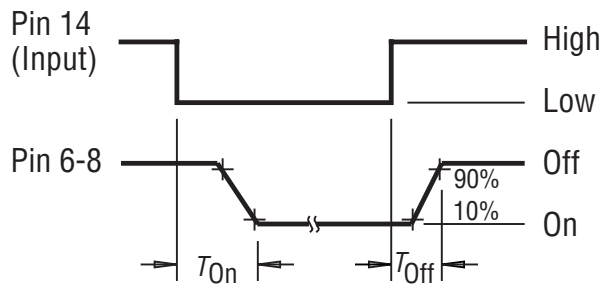
**Figure 1 - Maximum Input Current vs. Input Voltage**



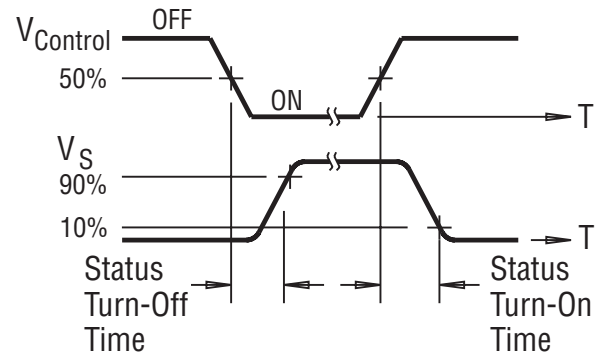
**Figure 2 - Series Resistance vs. Vcc Supply Voltage (Note 1)**



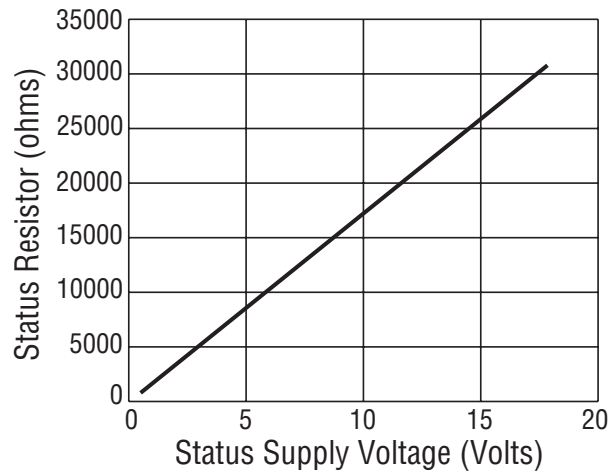
**Figure 3 - Turn-on and Turn-off Timing**



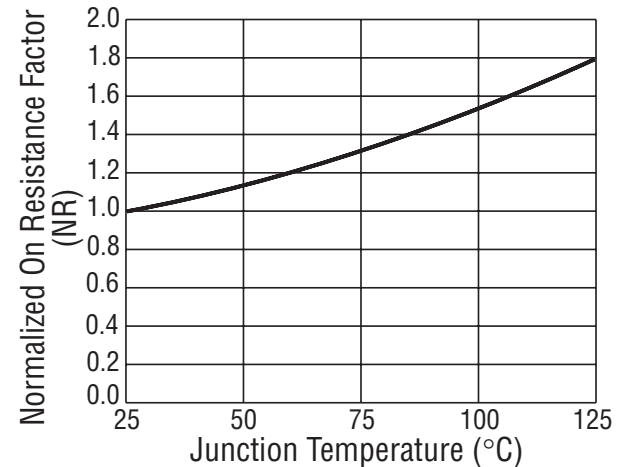
**Figure 4 - Output Status Timing**



**Figure 5 - Status Resistor vs. Status Supply Voltage**

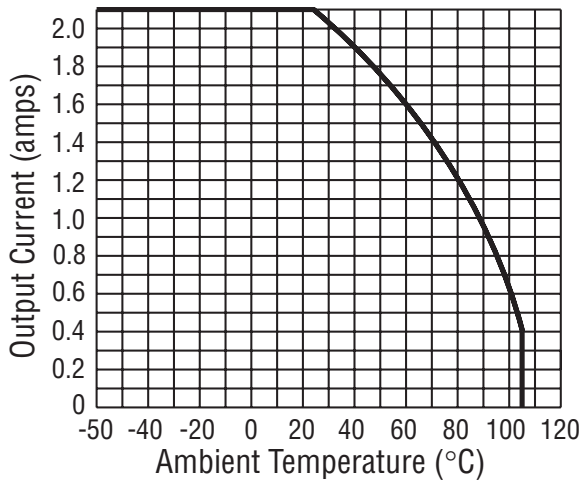


**Figure 6 - On-Resistance vs. Temperature (Note 6)**

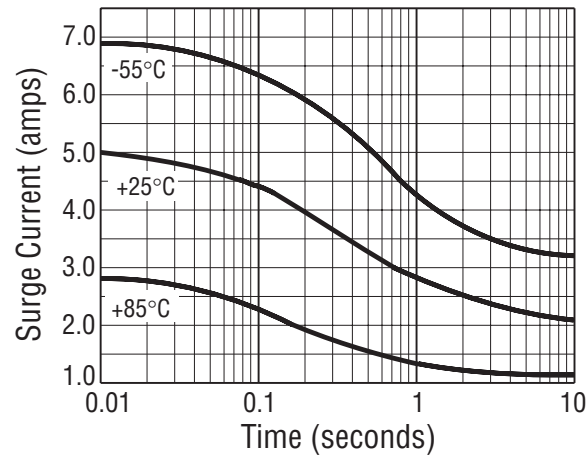


**DS11 Series SSR For DC Loads up to 2A @ 60Vdc** (Continued)

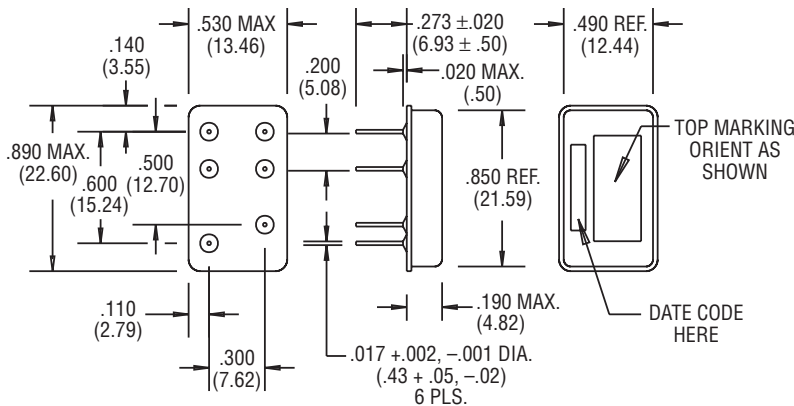
**Figure 7 - Temperature Derating Curve**



**Figure 8 - Maximum Surge Current Without Tripping**



**Figure 9 - Outline Dimensions**



TOLERANCE:  
 ± 0.010 (0.25mm) FOR 2 PLACE DECIMALS,  
 ± 0.005 (0.13mm) FOR 3 PLACE DECIMALS.  
 UNLESS OTHERWISE SPECIFIED

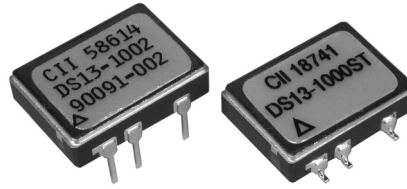
**Notes**

1. 2 terminal input configuration is compatible with CMOS or open collector TTL (with pull-up resistor). For Vcc levels above 6Vdc, a series limiting resistor is required. See Fig. 2 for resistor value. Use standard resistor value equal to or less than value from the curve.
2. Input transitions to be ≤ 1ms duration, and input direct drive should be “bounceless contact” type.
3. Vcc = 5Vdc for all tests unless otherwise specified.
4. All DS11 Series relays may drive loads connected to either positive or negative referenced power supply lines. Reversing polarity of output may cause permanent damage. Inductive loads must be diode suppressed.
5. Transient blocking voltage and electrical system spike tests are performed per MIL-STD-704 (28VDC systems).
6. To determine the maximum on-resistance at any given junction temperature, multiply on-resistance at 25°C (0.15 ohm) by normalized on-resistance factor from curve (Fig. 6).
7. Overload testing per MIL-R-28750 is constrained to the limits imposed by the short circuit protection requirements of this specification and DSCC drawing 88062. Load circuit series inductance for “load shorted” mode of operation to be limited to 50mH max. Maximum repetition rate into a shorted load should not exceed 10 Hz.
8. Proper operation of the status feedback requires a status pull-up resistor. See Fig. 5 for status resistor value.

## DS13 SSR for loads up to 2A @ 60Vdc

### Product Facts

- Standard options: short circuit/overload protection and control status.
- Optically coupled all solid state relay.
- TTL & CMOS compatible input.
- Low on-resistance power MOSFET output.
- Tested per MIL-PRF-28750D and approved to DSCC drawing 90091.
- All versions available with Tyco Electronics "W" level screening for Kilovac relays.



DS13 series SSRs employ state of the art photovoltaic optical isolation and power MOSFET output chips for ultra-reliable high speed switching of DC loads up to 2 amps, with low on-resistance. Standard options include integral current overload/short

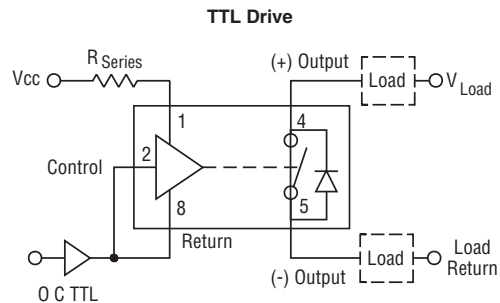
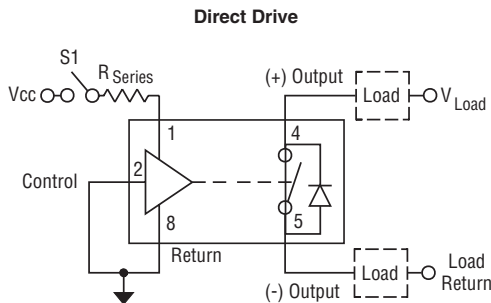
circuit protection and a separate input control status line. The overload feature provides protection of the relay, load and load circuit wiring in the event of a sustained current overload or short circuit while the relay is on or when it is turned on into a short. The

control status provides a built-in test function which provides a logic "0" when the input circuit is energized and functional. The relay is packaged into a custom hermetically sealed low-profile 8-pin ceramic DIP package, with through hole or surface mount pins.

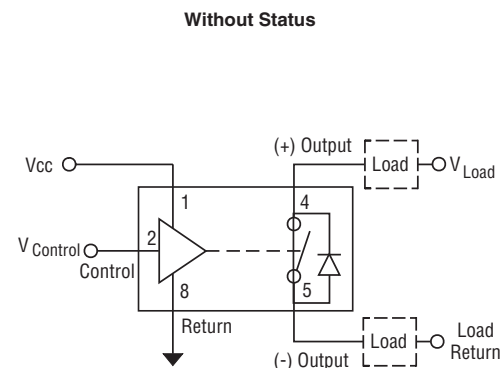
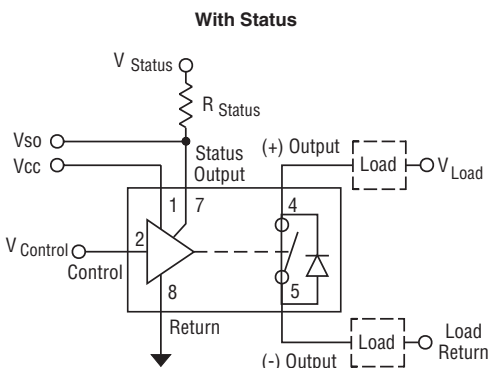
Kilovac Part No.	DSCC Dwg. No.	Relay Version
<b>DS13-1Y</b>	90091-008	Basic relay
<b>DS13-1000</b>	90091-004	Relay w/ short circuit protection
<b>DS13-1001</b>	90091-006	Relay w/ control status
<b>DS13-1002</b>	90091-002	Relay w/ short circuit protection and control status

Notes: Add suffix "S" to part number for surface mount versions.  
 Add suffix "T" to part number for tinned leads.  
 Add suffix "W" to part number for lower screening level.

### 2 Terminal Input Configuration



### 3 Terminal Input Configuration



**DS13 SSR for loads up to 2A @ 60Vdc** (Continued)

**Environmental Characteristics**
**Ambient Temperature Range:**

 Operating: -55°C to +105°C.  
 Storage: -55°C to +125°C.

**Vibration Resistance:**

100 G's, 10-3,000 Hz.

**Shock Resistance:**

1,500 G's, 0.5 ms pulse.

**Constant Acceleration Resistance:**

5,000 G's.

**Mechanical Characteristics**
**Weight (max.):**

.07 oz. (2 grams)

**Materials:**

 Case: DIP, hermetically sealed,  
 ceramic  
 Pins: Copper, gold plated

**Electrical Specifications (-55°C to +105°C unless otherwise specified)**
**Input (2 terminal configuration)**

Input supply voltage range (Vcc)	3.8 - 32 Vdc (Notes 1 & 2, Figures 1 & 2)
Input current (max.) @ 5Vdc	15mAdc (Notes 1 & 2, Figures 1 & 2)
Must turn-on voltage	3.8Vdc
Must turn-off voltage	1.5Vdc
Reverse voltage protection	-32Vdc

**Input (3 terminal configuration)**

Control voltage range	0 - 18 Vdc
Control current (max.)	240µAdc @ 5V, 1mA @ 18V
Input supply voltage range (Vcc)	3.8 - 32 Vdc (Notes 1 & 2, Figures 1 & 2)
Input current (max.) @ 5Vdc	15mAdc (Notes 1 & 2, Figures 1 & 2)
Must turn-on voltage	0.3Vdc
Must turn-off voltage	3.2Vdc

**I/O**

Dielectric Strength (min.)	1,000V rms
Insulation Resistance (min.) @ 500Vdc	10 <sup>9</sup> ohms
Capacitance (max.)	10pF

**Output**

Continuous load current (max.) @ 25°C, without short circuit protection	2.0Adc (Figure 5, Note 3)
Continuous load current (max.) @ 25°C, with short circuit protection	1.0Adc (Figure 5, Note 3)
Continuous load voltage (max.)	60Vdc
Transient blocking voltage (max.)	80Vdc (Note 4)
On resistance (max.) @ T <sub>j</sub> = 25°C, I <sub>L</sub> = 100ma, with short circuit protection	0.45 ohm (Note 5, Figure 4)
On resistance (max.) @ T <sub>j</sub> = 25°C, I <sub>L</sub> = 100ma, without short circuit protection	0.22 ohm (Note 5, Figure 4)
Output voltage drop (max.), with short circuit protection	0.6Vdc
Output voltage drop (max.), without short circuit protection	0.75Vdc
Off-state leakage current (max.) @ 60Vdc	100µAdc
Turn-on time (max.)	1.5 ms (Figure 3)
Turn-off time (max.)	.25 ms (Figure 3)
dv/dt (min.)	100V / µs
Electrical system spike	±600Vdc (Note 4)
Junction temperature (max.)	150°C
Thermal resistance (max.), junction to ambient	80°C/W
Thermal resistance (max.), junction to case	20°C/W

**Status**

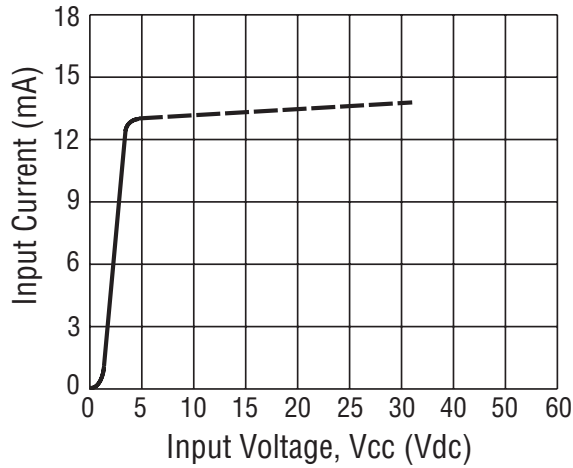
Status supply voltage	30Vdc
Status sink current (max.) @ Vstatus ≤ 0.3Vdc	2mAdc (Note 7)
Status leakage current (max.) @ 15Vdc	4µAdc

**Short Circuit Protection**

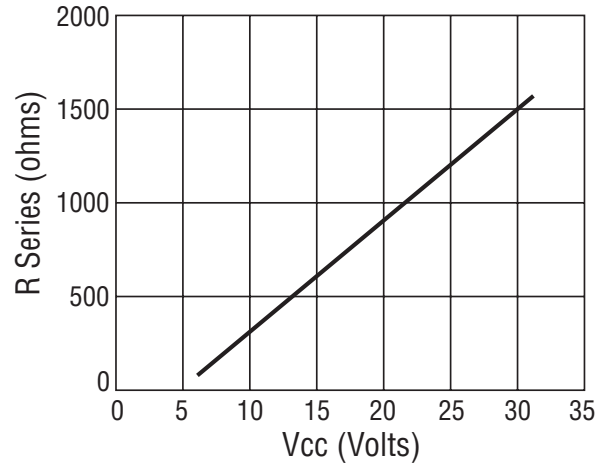
See Figure 6, Note 7

**DS13 SSR for loads up to 2A @ 60Vdc** (Continued)

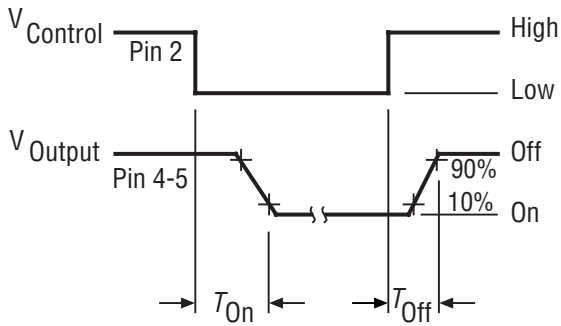
**Figure 1 - Maximum Input Current vs. Input Voltage**



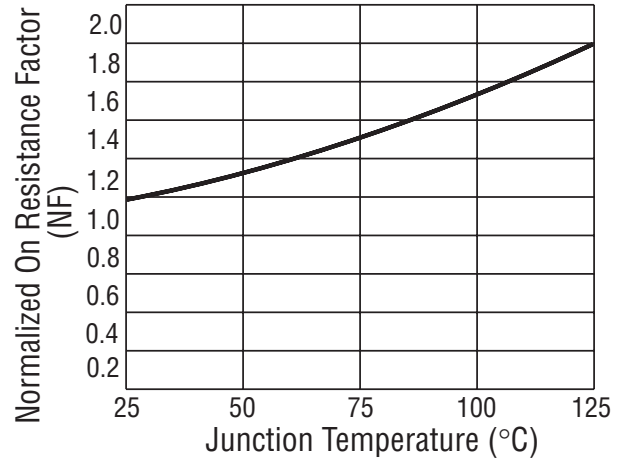
**Figure 2 - Series Resistance vs. Vcc Supply Voltage (Note 1)**



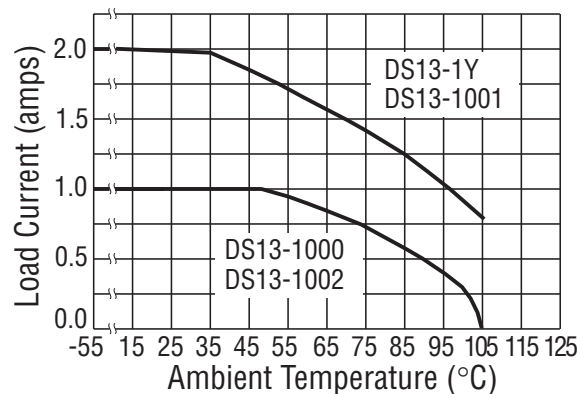
**Figure 3 - Output Turn-on and Turn-off Timing**



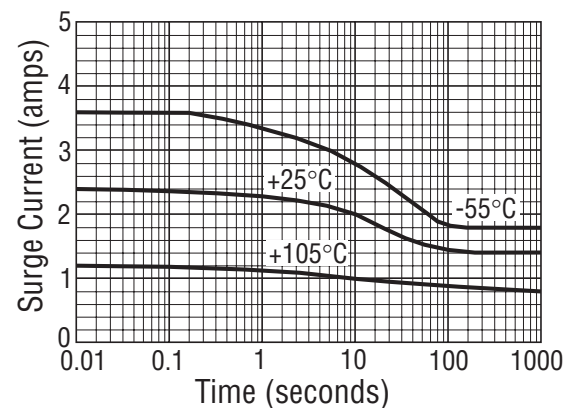
**Figure 4 - On-Resistance vs. Temperature (Note 6)**



**Figure 5 - Temperature Derating Curve**

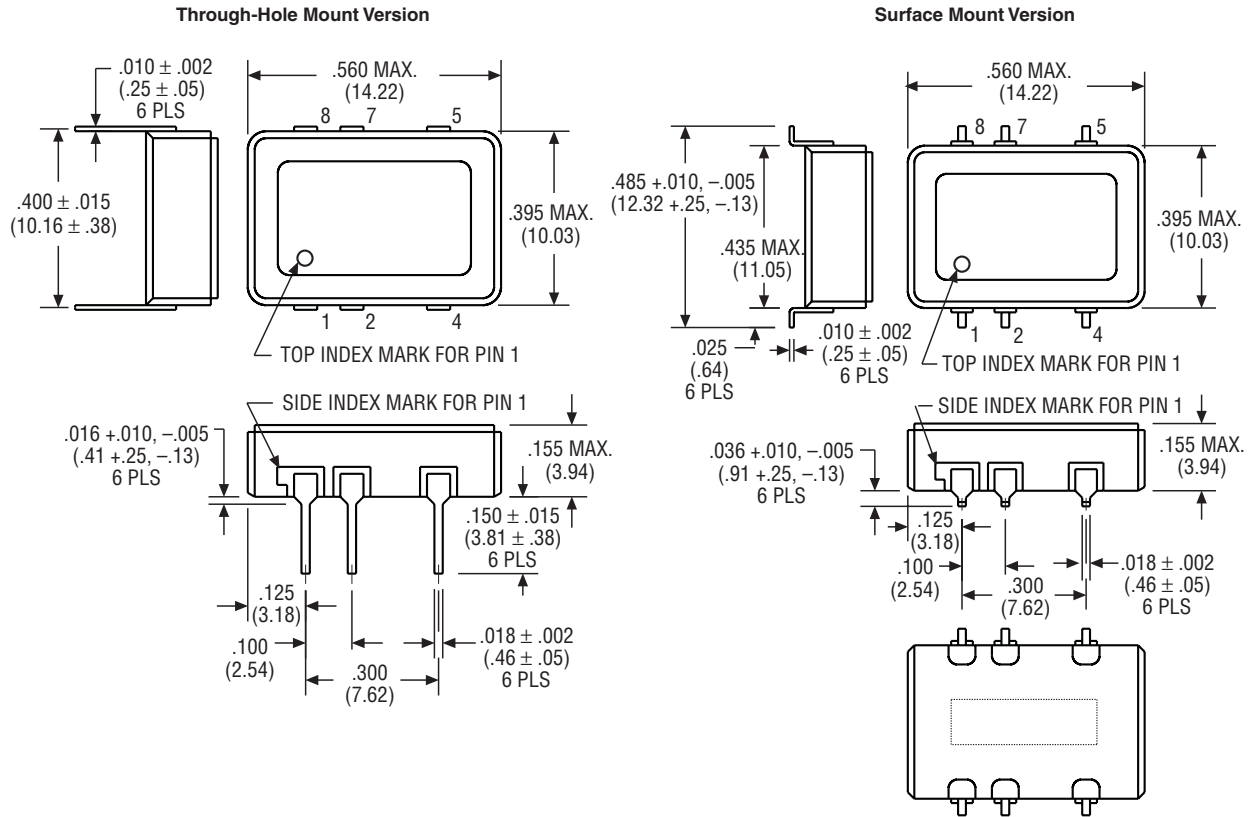


**Figure 6 - Typical Current Trip Levels**





**DS13 SSR for loads up to 2A @ 60Vdc** (Continued)

**Figure 7 - Outline Dimensions**


10  
 Kilovac Solid State Relays

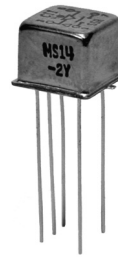
**Notes**

1. 2 terminal input configuration is compatible with CMOS or open collector TTL (with pull-up resistor). For Vcc levels above 6Vdc, a series limiting resistor is required. See Fig. 2 for resistor value. Use standard resistor value equal to or less than value from the curve.
2. Vcc = 5Vdc for all tests unless otherwise specified.
3. All DS13 Series relays may drive loads connected to either positive or negative referenced power supply lines. Reversing polarity of output may cause permanent damage. Inductive loads must be diode suppressed.
4. Transient blocking voltage & electrical system spike tests are performed per MIL-STD-704 (28Vdc systems).
5. To determine the maximum on-resistance at any given junction temperature, multiply on-resistance at 25°C by normalized on-resistance factor from curve (Fig. 4).
6. Overload testing per MIL-R-28750 is constrained to the limits imposed by the short circuit protection requirements of this specification and DSCC drawing 90091. Load circuit series inductance for "load shorted" mode of operation to be limited to 50mH max. Maximum repetition rate into a shorted load should not exceed 10 Hz. To calculate maximum on-resistance at any temperature, use the following equation:  $R(on) = R(on) @ 25^{\circ}C \times NF$  (without short circuit protection) and  $R(on) = 0.2 \times NF + .21$  (with short circuit protection) where NF = normalized on-resistance factor from Fig. 4.
7. Proper operation of the status feedback requires a status pull-up resistor. Select the status resistor such that it limits status output current to 2mA:  $R \text{ status} = \frac{V \text{ status} - 0.3V}{2mA}$ .

## MS14 Series Solid State Relay, With DC or Bi-Directional Output to 350mA @ 400V

### Product Facts

- 1000V optical isolation protects control and driver circuitry from load transients.
- Buffered/current limited input for direct drive from CMOS or TTL logic.
- Power MOSFET output chips for low voltage drop.
- 90 & 240mA output current.
- 85, 100 & 400V output voltage.
- Subminiature hermetically sealed .100 grid package.
- Screened per "Y" level of MIL-PRF-28750D.
- Direct replacement for TELEDYNE M92F & M93F series



MS14 series subminiature SSRs employ state of the art photo-voltaic optical isolation providing 1000Vrms input/output isolation and power mosfet output chips for ultra-reliable

high speed switching of DC or bidirectional loads up to 350mA and 400Vdc. The input is current regulated and buffered to minimize power dissipation and permit driving the relay direct

from CMOS or TTL. The relay is packaged in a custom hermetically sealed low-profile .100 grid package which conserves space for high density PC board circuitry.

### Ordering Information

Kilovac Part No.	DSCC Drawing/Pin No.	Output Rating
<b>MS14-1Y</b>	85092-001	350mA / 400V
<b>MS14-2Y</b>	85092-002	135mA / 400V
<b>MS14-3Y</b>	87034-003	±240mA / 85V

### Environmental Characteristics

**Ambient Temperature Range:**  
Operating: -55°C to +105°C.  
Storage: -55°C to +125°C.

**Vibration Resistance:**  
30 G's, 10-3,000 Hz.

**Shock Resistance:**  
1,500 G's, 0.5 ms pulse.

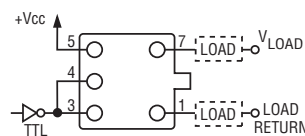
**Constant Acceleration Resistance:**  
5,000 G's.

### Mechanical Characteristics

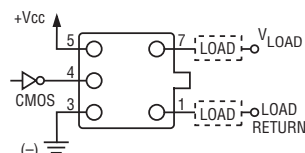
**Weight (max.):**  
.07 oz. (2 grams)

**Materials:**  
Case: Nickel, hermetically sealed.  
Pins: Kovar, gold plated

### TTL Configuration



### CMOS Configuration



### Electrical Specifications (-55°C to +105°C unless otherwise specified)

#### Input (TTL Drive)

Input supply voltage range (Vcc)	3.8 - 32 Vdc (Notes 1 & 2, Figures 1 & 2)
Input current (max.) @ 5Vdc	16mAdc (Notes 1 & 2, Figures 1 & 2)
Must turn-on voltage	3.8Vdc
Must turn-off voltage	1.5Vdc

#### Input (CMOS Drive)

Control voltage range	0 - 18 Vdc
Control current (max.)	250µAdc @ 5V, 1mA @ 18V
Input supply voltage range (Vcc)	3.8 - 32 Vdc (Notes 1 & 2, Figures 1 & 2)
Input current (max.) @ 5Vdc	16mAdc (Notes 1 & 2, Figures 1 & 2)
Must turn-on voltage	0.3Vdc
Must turn-off voltage	2.8Vdc

#### I/O

Dielectric Strength (min.)	1,000V rms
Insulation Resistance (min.) @ 500Vdc	10 <sup>9</sup> ohms

#### Output

Continuous load current (max.) @ 25°C: MS14-1Y	350mAdc
Continuous load current (max.) @ 25°C: MS14-2Y	135mAdc
Continuous load current (max.) @ 25°C: MS14-3Y	+/- 240mA
Continuous load voltage (max.) @ 25°C: MS14-1Y	100Vdc
Continuous load voltage (max.) @ 25°C: MS14-2Y	400Vdc
Continuous load voltage (max.) @ 25°C: MS14-3Y	+/- 85V
On resistance (max.) @ T <sub>j</sub> = 25°C, I <sub>L</sub> = 100mA: MS14-1Y	4 ohms
On resistance (max.) @ T <sub>j</sub> = 25°C, I <sub>L</sub> = 100mA: MS14-2Y	25 ohms
On resistance (max.) @ T <sub>j</sub> = 25°C, I <sub>L</sub> = 100mA: MS14-3Y	8 ohms
Off-state leakage I (max.) @ 80% max. V @ -55 to +25°C	1µA
Off-state leakage I (max.) @ 80% max. V @ =25 to +85°C	50µA
Junction temperature (max.)	150°C
Turn-on time (max.) MS14-1Y & -2Y	.7mS
Turn-on time (max.) MS14-3Y	2mS
Turn-off time (max.) (all versions)	1mS

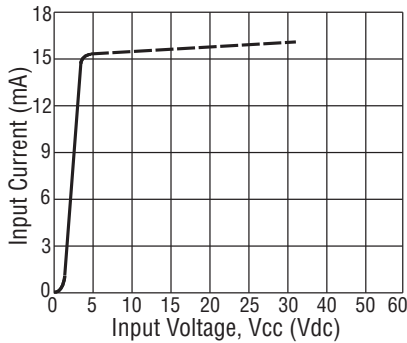
© 2011 by Tyco Electronics Corporation. All Rights Reserved.

TE logo and Tyco Electronics are trademarks.

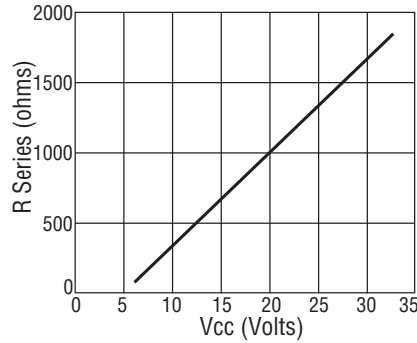
Other products and company names mentioned herein may be trademarks of their respective owners.

## MS14 Series Solid State Relay, With DC or Bi-Directional Output to 350mA @ 400V (Continued)

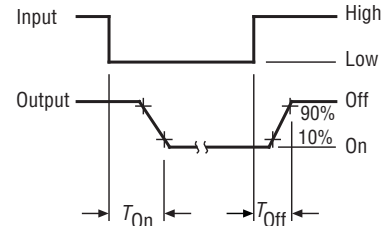
**Figure 1 -  
Max. Input Current vs. Input Voltage**



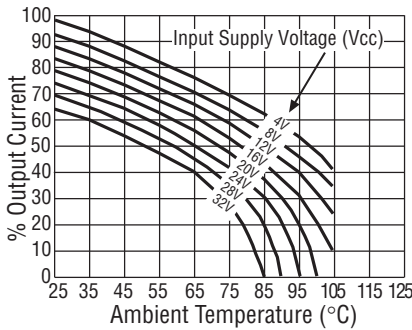
**Figure 2 -  
Series Res. vs. Vcc Supply Voltage (Note 1)**



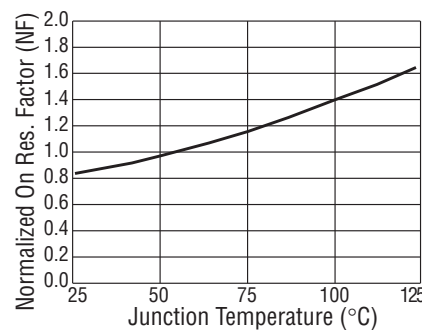
**Figure 3 -  
Output Turn-on and Turn-off Timing**



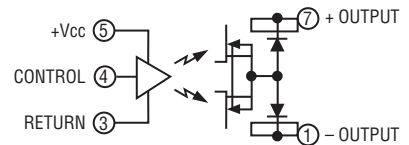
**Figure 4 -  
Temperature Derating Curve**



**Figure 5 -  
On-Resistance vs. Temperature (Note 6)**

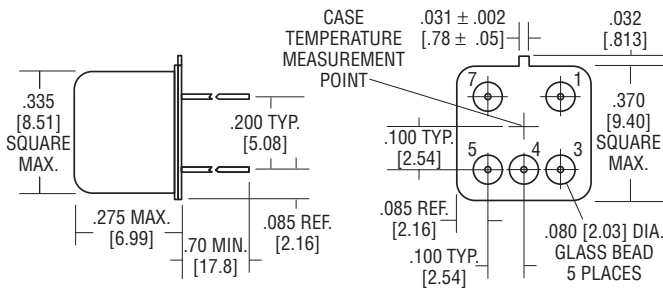


**Figure 6 -  
Simplified Circuit**



**Note:** MS14-1Y and -2Y have a single output chip.

**Figure 7 - Outline Dimensions**



Unless otherwise specified, tolerances are:  
±0.010 [0.25] for 2 place decimals  
±0.005 [0.13] for 3 place decimals

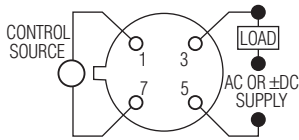
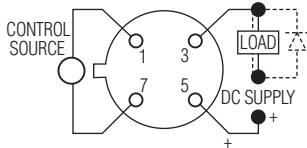
Terminal numbers are for reference only and do not appear on the header.

**Notes**

- 1.2 terminal input configuration is compatible with CMOS or open collector TTL (with pull-up resistor).
2. For Vcc levels above 6Vdc, a series limiting resistor is required. See Fig. 2 for resistor value. Use standard resistor value equal to or less than value from the curve.
3. Vcc = 5Vdc for all tests unless otherwise specified.
4. All MS14 Series relays may drive loads connected to either positive or negative referenced power supply lines. Inductive loads must be diode suppressed.
5. If an input series current limiting resistor is used, derating of output current vs. Vcc is not necessary. Curve for 4V applies.
6. On-resistance at any ambient temperature other than 25°C can be computed as follows:  
 $R (@ \text{any } T) = R (@ 25^\circ\text{C}) \times e^{0.006(T - 25)}$ , where T = new temperature - 25°C, e = 2.7182818.

9-1773439-2-PDF-KRG-9-07

## JTS5, 6, & 7 Series, DC & Bi-Directional Output, Up to 250mA & 250V Output Rating, TO-5 Package



Terminal View

### Product Facts

- Hermetically sealed TO-5 package
- Transformer coupled
- High speed switching
- JTS5-1Y switches AC or DC
- Qualified to M28750/5, 6, & 7

### Input Characteristics

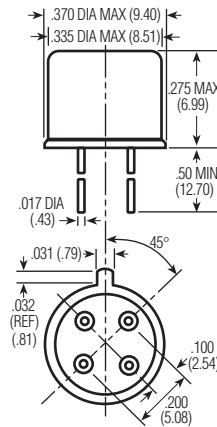
- Input Voltage Range** — 4.0 – 7.0 Vdc
- Maximum Turn-on Voltage** — 5.0 Vdc
- Minimum Turn-off Voltage** — 1.0 Vdc
- I/O Dielectric** — 1000 Vac pk-pk

### Output Characteristics

- Max. Output Current (Continuous, 25°C)** — 50 mAac or mAac (JTS5-1Y)  
250 mAac (JTS6-1Y)  
100 mAac (JTS7-1Y)
- Max. Output Voltage** — 40 Vac or Vdc (JTS5-1Y)  
40 Vdc (JTS6-1Y)  
250 Vdc (JTS7-1Y)
- Max. On-resistance** — 5 ohms (JTS5-1Y)
- Turn-on Time** — 10 μsec.
- Turn-off Time** — 15 μsec.

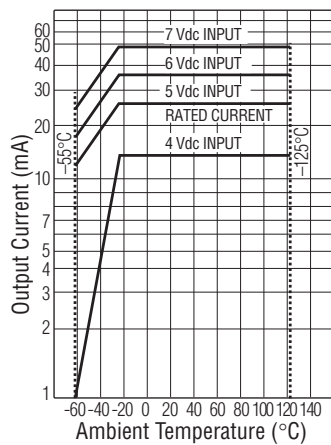
### Environmental Characteristics

- Shock** — 1500 G's, 0.5 ms.
- Vibration** — 100 G's, 10 to 2000 Hz
- Operating Ambient Temperature** — -55 to +125°C

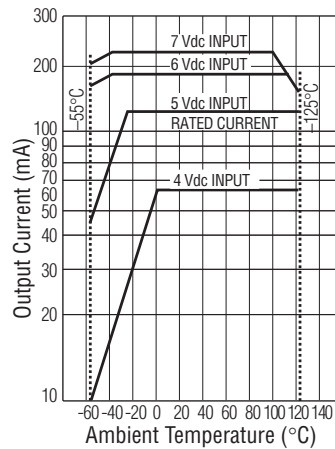


JTS5/JTS6/JTS7

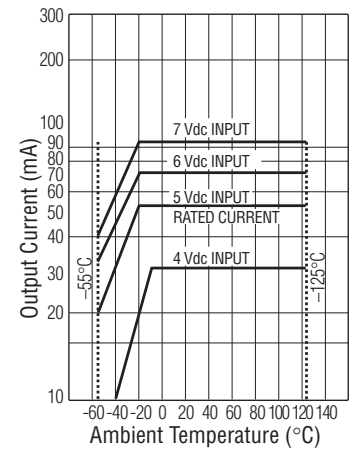
- Notes:**
- 1) Reversing polarity of input (or output except for JTS5-1) may cause permanent damage.
  - 2) Input must be a step function. Rise or fall time, as applicable, not to exceed 100 μsec.
  - 3) Inductive loads must be diode suppressed.
  - 4) For any control voltage, the maximum load current shown on graphs must not be exceeded. Attempting to draw currents in excess of those specified on graphs can cause permanent damage.



JTS5-1Y



JTS6-1Y



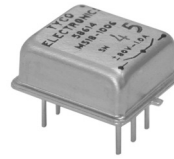
JTS7-1Y

Output Current Vs. Input Control Voltage and Ambient Temperature

## MS18-1006 High Performance DC and Bi-directional Solid State Relay For Loads up to 2A @ 80Vdc

### Product Facts

- Bi-directional power FET output
- Optically coupled
- Low on-resistance
- Extremely low leakage current
- Subminiature hermetically sealed package
- Tested per MIL-PRF-28750D and approved to DSCC drawing 89116-006



The MS18-1006 is an optically coupled SSR employing power MOSFET output chips in an inverse series configuration for switching DC or bi-directional loads. A common source connection is provided for the user

to configure the output switching circuit for DC operation up to 2A with very low on-resistance. The relay features fast switching speeds, low off-state leakage, virtually zero offset voltage and the capability to with-

stand high inrush currents up to 350% of rated. The low profile subminiature package is hermetically sealed with pinouts on a 0.1" x 0.3" grid pattern.

10 Kilovac Solid State Relays

Kilovac Part No.	DSCC Dwg. No.	Relay Version
MS18-1006	89116-006	Basic relay

### Environmental Characteristics

**Ambient Temperature Range** —  
 Operating — -55°C to +120°C  
 Storage — -55°C to +125°C

**Vibration Resistance** —  
 100 G's, 10-2,000 Hz

**Shock Resistance** —  
 1,500 G's, 0.5 ms pulse

**Constant Acceleration Resistance (Y-1 axis)** —  
 5,000 G's

### Mechanical Characteristics

**Weight (approx.)** —  
 .07 oz. (5 grams)

**Materials** —  
 Header — Kovar® Alloy  
 Cover — Grade A Nickel  
 Pins — Kovar® Alloy, gold plated

KOVAR is a trademark of Carpenter Technology Corporation.

### Electrical Specifications (-55°C to +120°C unless otherwise specified)

Input	
Input current (max.)	25mA <sub>dc</sub>
Input voltage drop (max. @ 25mA))	1.5 V <sub>dc</sub>
Must turn-on current	10mA
Must turn-off current	10µA
Reverse voltage protection	-5.0V <sub>dc</sub>
I/O	
Dielectric strength (60Hz., 1mA leakage)	500V rms
Insulation resistance (min.) @ 500V <sub>dc</sub>	10 <sup>9</sup> ohms
Capacitance (max. @ 25V <sub>dc</sub> , 1 Mhz)	5pF
Output	
Continuous load current, parallel (DC) configuration (max.)	2A (Figure 2)
Continuous load current, series (bi-directional) configuration (max.)	1A (Figure 2)
Continuous operating load voltage (max.)	+/- 80V
Transient blocking voltage (5 sec max.)	+/- 90V
Overload (100ms, 10% duty cycle, 10 cycles max.)	350% of rated
dv/dt (min.)	100V / µs
On resistance (max.), parallel (DC) configuration	0.4 ohm
On resistance (max.), series (bi-directional) configuration	0.6 ohm
Turn-on time (max, @ +/- 80V)	800µs (Figure 3)
Turn-off time (max, @ +/- 80V)	500µs (Figure 3)
Thermal resistance, junction to ambient	110°C/W
Thermal resistance, junction to case	20°C/W

Figure 1 – Wiring Diagrams



## MS18-1006 High Performance DC and Bi-directional Solid State Relay For Loads up to 2A @ 80Vdc (Continued)

Figure 2 - Temperature Derating Curves

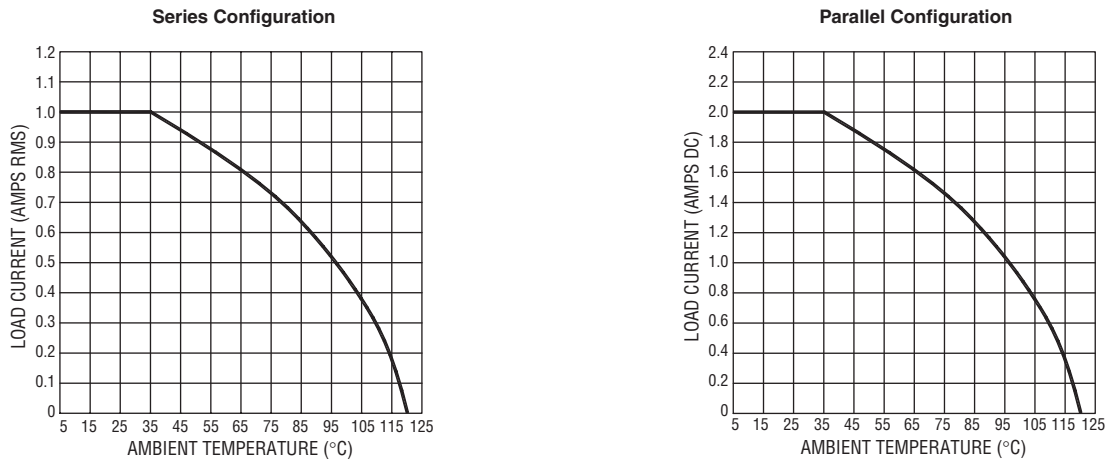


Figure 3 - Turn-on and Turn-off Timing

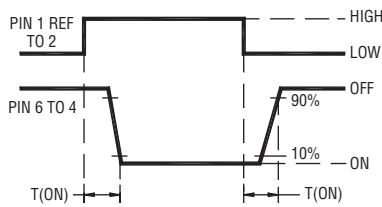


Figure 4 - Functional Block Diagram

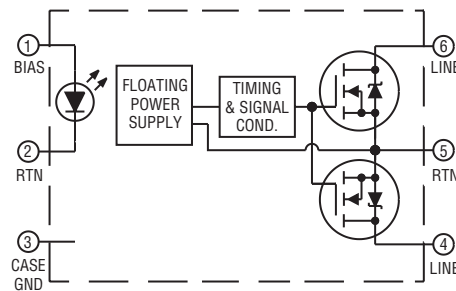
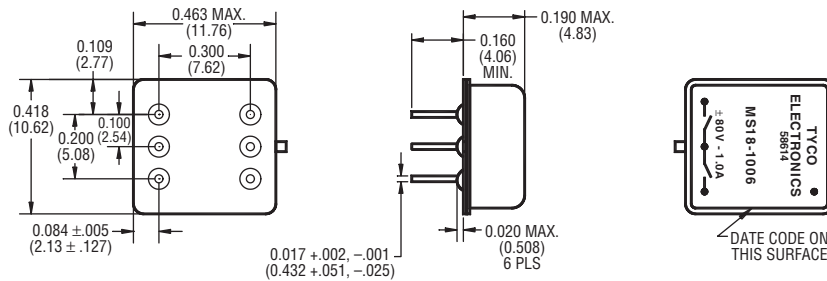


Figure 5 - Outline Dimensions



**Notes**

1. An external resistor must be in series with the input at all times.
2. Do not ramp input current. Input transition should be <1.0ms.
3. Input current/series resistor calculation (Approx.):  $I_{(input)} = V_{IN} - V_{DROPP} / R_{SERIES}$ .
4. Unless otherwise specified parametric testing is accomplished at 25ma input current.
5. To calculate  $R_{DS(ON)}$  for temperatures other than 25°C, use the following equation:  $T_{(TEMP)} = (R_{DS(ON)} \text{ at } +25^{\circ}\text{C}) \cdot e^{(x \cdot \Delta T)}$  where  $x = 0.0065$ .
6. Inductive loads must be diode suppressed.
7. Continuous load current is rated under conditions of still air.
8. Load may be connected to either side of relay, sink or source modes.
9. Reverse polarity >5Vdc may cause permanent damage
10. Acceptance testing is accomplished in the series (bi-directional) mode.
11. DSCC part numbers 89116-002 & 89116-004 are also available.

## JDS9 Series, AC Relays, 2A/250Vrms Rating



### Input Characteristics

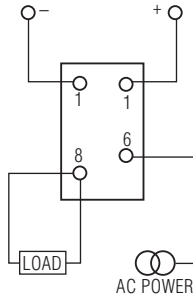
- Input Voltage Range** — 3.8 – 32 Vdc
- Pick-up Voltage** — 3.8 Vdc
- Dropout Voltage** — 1.5 Vdc
- I/O Dielectric** — 1500 Vrms

### Output Characteristics

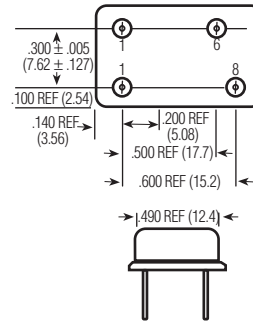
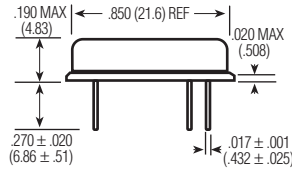
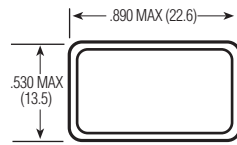
- Max. Output Current (Continuous, 25°C)** — 2 Arms
- Max. Output Voltage** — 250 Vrms
- Peak Over Voltage Rating** — 500 Vpk
- Frequency Range** — 40 – 440 Hz
- Zero Switch Window** — 15 Vpk
- Thermal Resistance** —  
 Junction to Ambient — 65°C/Watt  
 Junction to Case — 15°C/Watt

### Environmental Characteristics

- Shock** — 1500 G's, 0.5 ms.
- Vibration** — 30 G's, 10 to 3000 Hz
- Operating Ambient Temperature** — -55 to +110°C



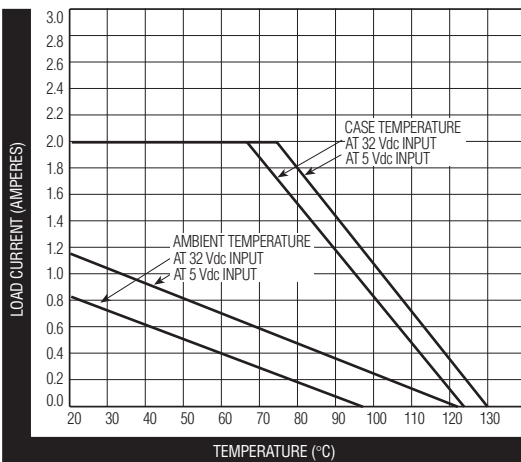
Terminal View



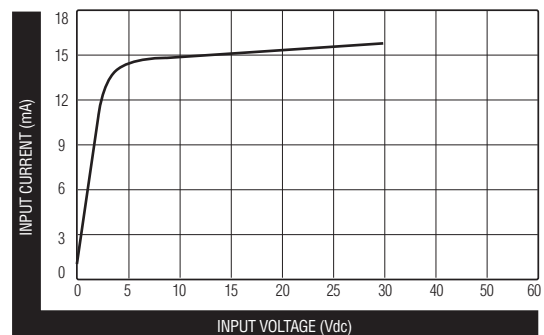
JDS9-1Y

### Product Facts

- Hermetically sealed
- Thick film hybrid construction
- Optically isolated
- Zero voltage turn-on
- Qualified to MIL-R-28750/9



JDS9 Max. Output Current vs. Temperature



JDS9 Typical Input Current vs. Input Voltage

10 Kilovac Solid State Relays

**JDS9 Series, AC Relays, 2A/250Vrms Rating** (Continued)

**Electrical Specifications (-55°C to +105°C unless otherwise specified)**

<b>Input</b>	
Input supply voltage range (Vcc)	3.8 - 32 Vdc
Input current (max.) @ 5Vdc	15mA <sub>dc</sub>
Must turn-on voltage	3.8V <sub>dc</sub>
Must turn-off voltage	1.5V <sub>dc</sub>
Reverse voltage protection	-32V <sub>dc</sub>
<b>I/O</b>	
Dielectric strength (min.)	1,500V rms/60 Hz.
Insulation resistance (min.) @ 500Vdc	10 <sup>9</sup> ohms
Capacitance (max.)	10pF
<b>Output</b>	
Output current rating (max.)	2A rms (Fig. 2, Note 1)
Surge current (max.), 16ms @ 25°C (max.)	8A pk (Fig. 1, Note 3)
Continuous load voltage (max.)	250V rms
Transient blocking voltage (max.)	500V pk
Frequency range	40 - 440 Hz.
Output voltage drop (max.) @ 1A load current	1.5V rms
Off-state leakage current (max.) @ 250V rms/400 Hz.	1mA rms
Turn-on time (max.)	1/2 cycle
Turn-off time (max.)	1 cycle
Off-state dv/dt (min.), with snubber	200V /μs (Note 2)
Zero voltage turn-on window (max.)	10V
Wave distortion (max.)	4V rms
Output chip junction temperature (max.)	130°C
Thermal resistance (max.), junction to ambient	65°C/W
Thermal resistance (max.), junction to case	15°C/W

**Notes**

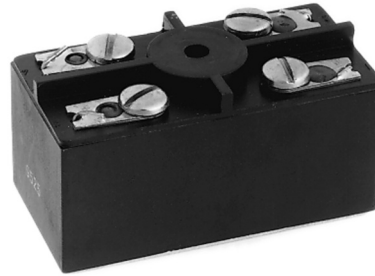
1. Operation at elevated load currents up to 2 amps is dependent on the use of suitable heatsink to maintain case temperature.
2. Recommended output snubber: R = 100 ohms (1/2 W), C = .01μF (600V).
3. Heating of output chip during and after a surge may cause loss of output blocking capability until junction temperature falls below maximum rating.



## PS12 Series High Performance Solid State Relays For AC Loads up to 10A @ 250Vrms

### Product Facts

- Approved to DSCC drawing 86031
- Optically coupled all solid state relay
- TTL compatible input
- Zero voltage turn-on for low EMI
- Custom power package with screw terminals



The PS12 series solid state relay is designed for AC power switching up to 10 amps at 250Vrms. The circuit employs back-to-back SCRs with zero voltage turn-on for reliable switching of

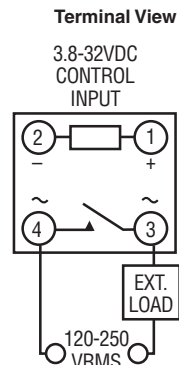
resistive or reactive loads. TTL compatible input circuitry is optically isolated to 1,500Vrms from the AC load circuit. The relay is offered in two versions: the PS12-1Y with "Y" level screening per

MIL-PRF-28750D, and the PS12-1W screened per Tyco Electronics specifications for Kilovac relays, equivalent to former "W" level of Mil-R-28750.

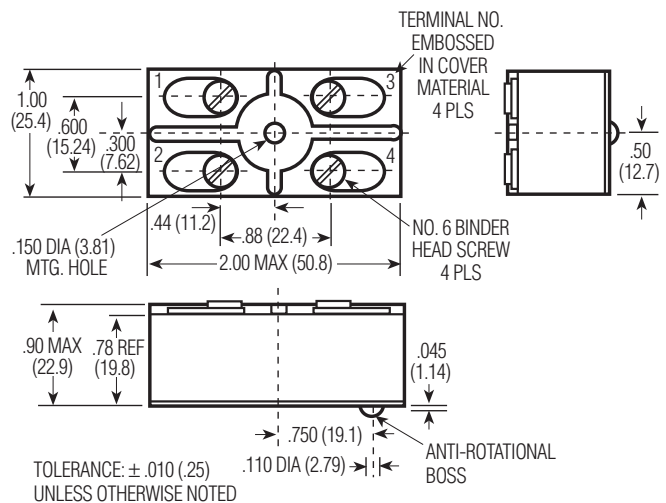
10  
Kilovac Solid State Relays

Kilovac Part Number	DSCC Part Number	Screening Level
PS12-1Y	86031-001	Y
PS12-1W	N/A	W

### Circuit Diagram



### Outline Drawing



## PS12 Series High Performance Solid State Relays For AC Loads up to 10A @ 250Vrms (Continued)

### Environmental Characteristics

#### Ambient Temperature Range —

Operating — -55°C to +95°C  
Storage — -55°C to +110°C

#### Vibration Resistance —

30 G's, 78-2,000 Hz

#### Shock Resistance —

100 G's, 6 ms pulse

#### Constant Acceleration Resistance —

100 G's

### Mechanical Characteristics

#### Weight (max.) —

3 oz. (85 grams)

#### Materials —

Case — Plastic, self-extinguishing, epoxy filled

Terminals — Brass, nickel-plated

Base Plate — Aluminum

**NOTE:** Do not exceed 125 in-oz when tightening screws.

### Electrical Specifications (-55°C to +95°C unless otherwise specified)

#### Input

Input supply voltage range (Vcc)	3.8 - 32 Vdc
Input current (max.) @ 5Vdc	16mAdc
Must turn-on voltage	3.8Vdc
Must turn-off voltage	1Vdc
Reverse voltage protection	-32Vdc

#### I/O

Dielectric strength (min.)	1,500V rms/60 Hz.
Insulation resistance (min.) @ 500Vdc	10 <sup>9</sup> ohms
Capacitance (max.)	15pF

#### Output

Output current rating (max.)	10A rms (Fig. 2, Note 1)
Surge current (max.)	100A pk (Fig. 1, Note 2)
Continuous load voltage (max.)	250V rms
Transient blocking voltage (max.)	460V pk
Frequency range	45 - 440 Hz.
Output voltage drop (max.) @ 25A load current	1.5V rms
Off-state leakage current (max.) @ 220V rms/400 Hz.	9mA rms
Turn-on time (max.)	1/2 cycle
Turn-off time (max.)	1 cycle
Off-state dv/dt (min.), with snubber	200V / $\mu$ s (Note 3)
Zero voltage turn-on window (max.)	$\pm$ 15V pk
Output chip junction temperature (max.)	125°C (Note 1)
Thermal resistance (max.), junction to ambient	11.5°C/W
Thermal resistance (max.), junction to case	2.0°C/W
Fusing I <sup>2</sup> T, 1 ms (max.)	150A <sup>2</sup> s
Load power factor (min.)	0.2
Power dissipation (max.)	1.5W/A

### Notes

1. Operation at elevated load currents up to 10 amps is dependent on the use of suitable heatsink to limit junction temperature.
2. Heating of output chips during and after a surge may cause loss of output blocking capability until junction temperature falls below maximum rating.
3. Internal snubber network is provided across output chips.

Figure 1 - Peak Surge Current vs. Surge Current Duration

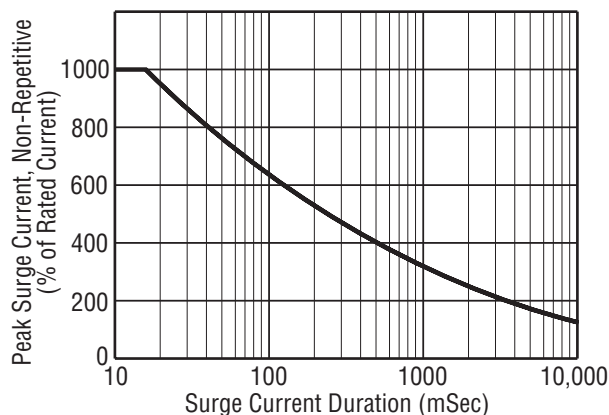
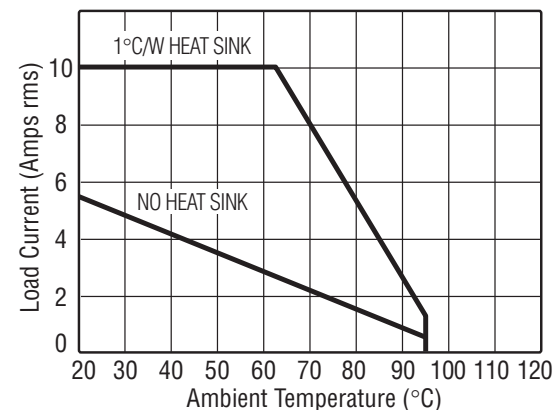


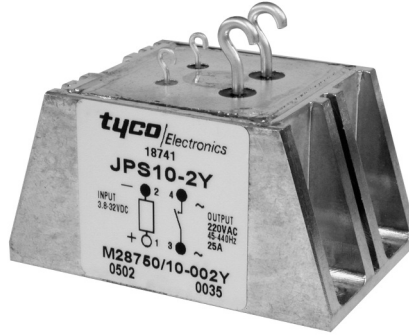
Figure 2 - Load Current vs. Temperature



## JPS10 Series High Performance Solid State Relays For AC Loads up to 25A @ 250Vrms

### Product Facts

- Qualified to MIL-PRF-28750D (Mil Part Numbers M28750/10-001Y and M28750/10-002Y)
- Optically coupled all solid state relay
- TTL compatible input
- Zero voltage turn-on for low EMI
- Custom power package



The JPS10 series solid state relay is designed for AC power switching up to 25 amps at 250Vrms. The circuit employs back-to-back photo SCRs with zero voltage turn-on for reliable

switching of resistive or reactive loads. TTL compatible input circuitry is optically isolated to 1,500Vrms from the AC load circuit. The relay is offered in two versions: the JPS10-1Y with a maximum

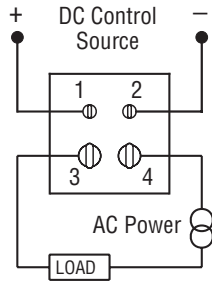
zero voltage turn-on window of 15 volts (preferred version for resistive loads), and the JPS10-2Y with a maximum window of 40 volts (preferred version for reactive loads).

10 Kilovac Solid State Relays

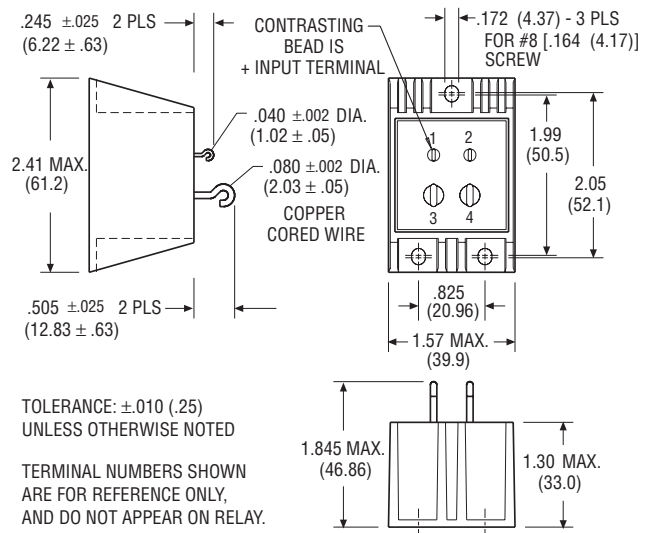
Kilovac Part Number	Military Part Number	Zero Crossing Window
JPS10-1Y	M28750/10-001Y	15 V pk max.
JPS10-2Y	M28750/10-002Y	40 V pk max.

### Circuit Diagram

#### Terminal View



### Outline Drawing



## JPS10 Series High Performance Solid State Relays For AC Loads up to 25A @ 250Vrms (Continued)

### Environmental Characteristics

**Ambient Temperature Range** —  
Operating — -55°C to +110°C  
Storage — -55°C to +125°C

**Vibration Resistance** —  
30 G's, 10-3,000 Hz

**Shock Resistance** —  
1,500 G's, 0.5 ms pulse

**Constant Acceleration Resistance (Y1 axis)** —  
5,000 G's

### Mechanical Characteristics

**Weight (max.)** —  
6 oz. (170 grams)

**Materials** —  
Case — Aluminum, hot tin dipped  
Terminals — Copper cored wire, gold plated

### Electrical Specifications (-55°C to +105°C unless otherwise specified)

#### Input

Input supply voltage range (Vcc)	4 - 32 Vdc
Input current (max.)	16mAdc
Must turn-on voltage	4Vdc
Must turn-off voltage	1Vdc
Reverse voltage protection	-32Vdc

#### I/O

Dielectric strength (min.)	1,500Vrms/60 Hz.
Insulation resistance (min.) @ 500Vdc	10 <sup>9</sup> ohms
Capacitance (max.)	20pF

#### Output

Output current rating (max.)	25Arms (Fig. 2, Note 1)
Surge current (max.)	80A pk (Fig. 1, Note 2)
Continuous load voltage (max.)	250Vrms
Transient blocking voltage (max.)	500V pk
Frequency range	45 - 440 Hz.
Output voltage drop (max.) @ 25A load current	1.5Vrms
Off-state leakage current (max.) @ 220Vrms/400 Hz.	10mArms
Turn-on time (max.)	1/2 cycle
Turn-off time (max.)	1 cycle
Off-state dv/dt (min.), with snubber	100V/μs (Note 3)
Zero voltage turn-on window (max.), JPS10-1Y	15V pk
Zero voltage turn-on window (max.), JPS10-2Y	40V pk
Waveform distortion (max.)	4Vrms
Output chip junction temperature (max.)	125°C (Note 4)
Thermal resistance (max.), junction to ambient	6.8°C/W
Thermal resistance (max.), junction to case	1.2°C/W

### Notes

1. Operation at elevated load currents up to 25 amps is dependent on the use of suitable heatsink to maintain case temperature per Fig. 2.
2. Heating of output chips during and after a surge may cause loss of output blocking capability until junction temperature falls below maximum rating.
3. Internal snubber network is provided across output chips.
4. Case temperature measurement point is center of mounting surface.

Figure 1 - Peak Surge Current vs. Surge Current Duration

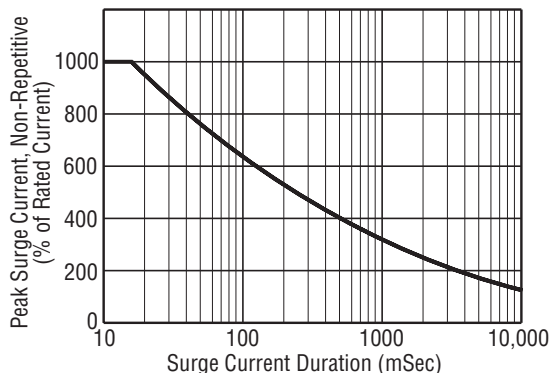


Figure 2 - Load Current vs. Temperature

